

CARE AND OPERATING INSTRUCTIONS FOR MAGNETIC DRIVE 2-7 & PONDMASTER® 250-700 PUMPS

ITEM # 02512,02515 and ITEM# 02522,02525

02513,02517

02523,02527

FEATURES

The pump is a magnetically driven centrifugal water pump. It has no seals to wear and contains no oil. The pump can be used submerged or inline. Inline means connections are made directly to the pump inlet and outlet ports, which have ½" NPT threads. All electrical components are encapsulated in epoxy. The energy used is approximately 1/2 of regular driven pumps. The prefilter is provided for use in situations where deposits in the water could clog or damage the pump. This helps to give uninterrupted service.

INLINE PIPING

Centrifugal pumps cannot pull water from a lower level. In order to start, pump must be below water level and filled with water. Unless the air can escape from the outlet, the pump will not start. Do not use glues or solvents to connect the pumps threaded fittings. Use Teflon pipe tape. The pump cover is not designed to support long pipe runs or to correct pipe misalignment.

SERVICE AND MAINTENANCE

The pump cover should occasionally be removed to clean and inspect the impeller assembly. The impeller is the only serviceable item and can be pulled out of the body. Do not take the impeller apart. If it is worn or broken the entire impeller assembly should be replaced. This will restore the pump to original capacity. Pumps taken out of service for an extended period with fluid inside run the risk of forming a crust which may prevent subsequent starting. Saltwater should be flushed out with fresh water. Always check cord for sharp bends which can cause premature cracking. Do not use power cord to lift or move pump.

CAUTION

The pump is intended to pump water only. It cannot be used to pump oil, solvents, or gasoline. Although the pump will continue to run if there is no water, after 30 minutes damage may occur if allowed to run dry.

ELECTRICAL PRECAUTIONS

Always use a properly grounded outlet. Do not immerse plug in water. **DO NOT REACH INTO WATER TO REMOVE PLUG. TURN OFF CIRCUIT FIRST.** A "drip loop" should be provided. The "drip loop" is a loop in the cord below the level of the receptacle or plug that prevents water from traveling along the cord. The National Electric Code requires that a ground fault circuit interrupter (GFCI) be installed in the branch circuit supplying fountain or pond equipment. Your dealer can supply GFCI units. **NEVER REMOVE GROUND PIN FROM PLUG. WARNING: FOR YOUR PROTECTION ALWAYS UNPLUG THE UNIT FROM ITS POWER SOURCE BEFORE INSTALLING OR SERVICING. SHOULD THE UNIT APPEAR TO BE NOT WORKING DO NOT REACH, REMOVE OR DISASSEMBLE BEFORE YOU DISCONNECT POWER.**

LIMITED WARRANTY

E.G. Danner Mfg. Inc. will repair or replace any pump found to be defective as follows: Pump body, cover and filter and accessories within three years of original purchase. Impeller and internal moving parts within one year of original purchase. This warranty does not cover any replaceable filtering material supplied with the pump or filter as it is considered expendable. Damaging, cutting or altering power cord, removing or defacing product labels voids any warranty consideration. For warranty repair return only the part that is defective to our factory. Please include a dated proof of purchase and \$5.00 for postage and handling. Damages or injuries resulting from negligence or misuse of the product are not covered by warranty. This warranty gives you specific legal rights. You may have other rights which vary from state to state.

TO REMOVE /ATTACH BASE PLATE

To remove the base, strike with moderate force in the direction toward the pump cover. The latch will bend and the base will slide off the housing. To attach the base. Slide the base (latch first) on the pump cover side of the housing. Slide the base onto the dovetail mounting tracks until the latch snaps.

FLOW VS HEADHEIGHT

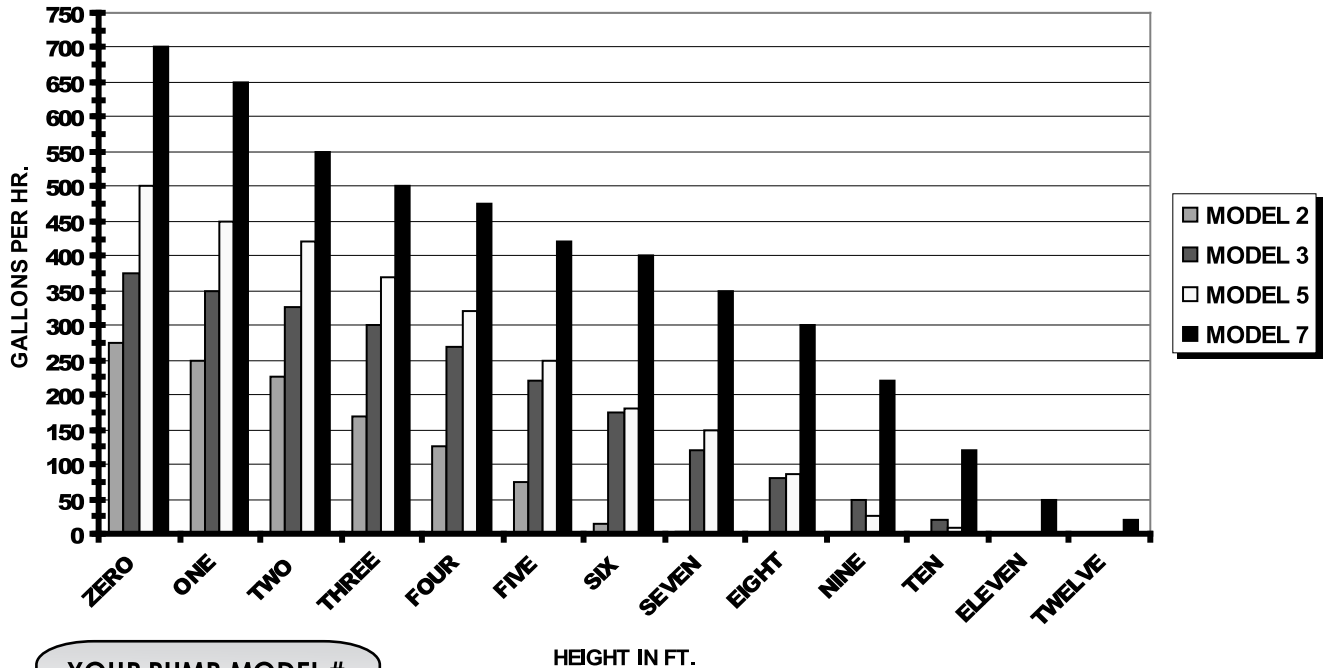

YOUR PUMP MODEL # IS ON THE PUMP NEAR ELECTRICAL CORD

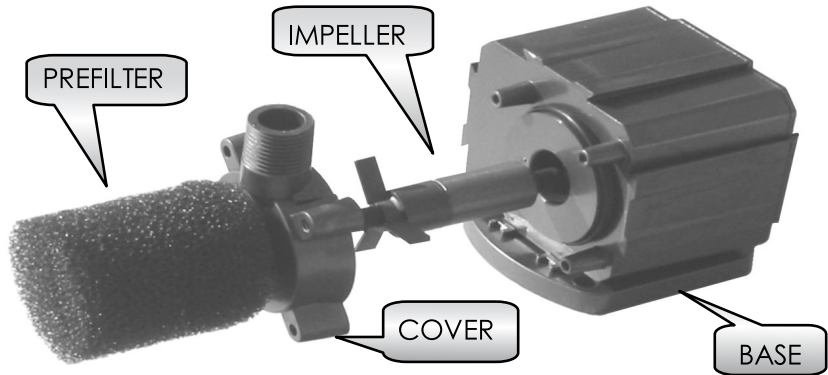
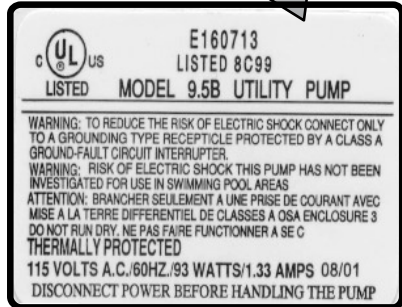

WARNING !: PONDS CAN BE DANGEROUS TO SMALL CHILDREN. NEVER LEAVE CHILDREN UNSUPERVISED NEAR A POND!

REPLACEMENT PARTS LIST

MODEL #	COMPLETE IMPELLER	PUMP COVER	PREFILTER	BASE	*PUMP COVER 3/4" BARB INLET
MODEL 2	12555	12535	12505	12515	12536
MODEL 3	12575	12535	12505	12515	12536
MODEL 5	12575	12545	12505	12515	12546
MODEL 7	12585	12545	12505	12515	12546
MAGNETIC DRIVE AND PONDMASTER MODELS USE SAME PARTS					
MODELS 2-7	* PUMP COVER USED ON PUMPS INCLUDED WITH PONDMASTER 1000 FILTER KITS				

DANNER MFG. INC. 160 OVAL DRIVE, ISLANDIA, NEW YORK 11749
 VISIT OUR WEB SITE: WWW.PONDMASTER.COM